

MEDICAL DEVICE INFORMATION PLATFORM AGREEMENT

This Medical Device Information Platform Agreement ("Agreement") is entered into on _____ ("Effective Date"), between CapsuleTech, Inc., located at 222 Jacobs Street, Cambridge, MA 02141 ("Philips Capsule"), and County of San Mateo, with its principal place of business at Redwood, City, CA 94063 ("Licensee").

BACKGROUND

Philips Capsule develops solutions that liberate data from medical devices, aggregates data centrally within the Medical Device Information Platform, analyze data in transit and share actionable insights for the full assigned care team within the Capsule Surveillance solution.

Licensee seeks to obtain from Philips Capsule the right to use the Philips Capsule Software subject to the terms and conditions of this Agreement.

AGREEMENT

1. DEFINITIONS

- 1.1 "Device Driver Interface" and/or "DDI" means a software module used as part of the Philips Capsule Software to connect to a specific Medical Device or hospital information system. The Philips Capsule Software is typically installed with multiple DDIs which can be used simultaneously. "DDI Library" means the collection of DDIs available on Philips Capsule's website.
- 1.2 "Documentation" means the user's guide, programmer's guide and help files included with the Philips Capsule Software.
- 1.3 "Error" means a defect or malfunction consisting of reproducible behavior by the Philips Capsule Software that does not correspond to the Documentation and that obstructs the use of the Philips Capsule Software.
- 1.4 "Facility" means Licensee's hospital or other health care facility located at the "ship to" address on Schedule A or documented on Schedule I.
- 1.5 "Hardware" means the hardware and accessories sold by Philips Capsule to Licensee.
- 1.6 "License" means the right to use the Philips Capsule Software in the Facility. The types of Licenses available as of the Effective Date are described in Schedule B and subject to the terms set forth in Schedule B. Licenses are specific to the Facility for which they are purchased and may not be transferred between Facilities without Philips Capsule's prior written consent. The types and numbers of Licenses being purchased by Licensee are specified in an Order.
- 1.7 "Medical Device" means a device that collects medical data via sensors or manual entry and for which Philips Capsule has a current DDI available.
- 1.8 "Order" means Schedule A to this Agreement or a subsequent order either signed by Licensee or issued by Licensee and accepted by Philips Capsule.
- 1.9 "Philips Capsule Software" means the specific Philips Capsule software products identified on an Order. The Philips Capsule Software also includes DDIs, Documentation and any Updates for such products provided to Licensee pursuant to this Agreement. Philips Capsule Software includes Philips Capsule MDI unless otherwise indicated in this Agreement.
- 1.10 "Support" means Philips Capsule's support and maintenance of the Philips Capsule Software, as more fully described in Section 5 and Schedule D.
- 1.11 "Update" means an updated version of the specific Philips Capsule Software products licensed to Licensee pursuant to this Agreement, including fixes, enhancements and new releases, but excluding anything that Philips Capsule licenses as a separate product.

2. **USE OF THE PHILIPS CAPSULE SOFTWARE**

- 2.1 **GENERAL LICENSE TERMS.** Philips Capsule grants to Licensee a non-exclusive, non-transferable right to use the Philips Capsule Software subject to Licensee complying with the terms and conditions of this Agreement, including payment for the proper number and type of Licenses. The specific type of license granted to Licensee, as more fully described on Schedule B, shall be set forth in the applicable Order.
- 2.2 **INTENDED USE STATEMENTS.** Schedule C sets forth the intended use statements for the individual Philips Capsule Software and Philips Capsule Hardware products. **LICENSEE ACKNOWLEDGES THAT IT HAS READ AND UNDERSTOOD THESE STATEMENTS, AND COVENANTS NOT TO USE THE PHILIPS CAPSULE PRODUCTS INCONSISTENT WITH, OR BEYOND THE SCOPE OF, THESE STATEMENTS, AND THAT PHILIPS CAPSULE WILL HAVE NO LIABILITY FOR ANY SUCH USE BY LICENSEE.**

3. **FEES, INVOICING AND PAYMENT**

- 3.1 The total fees approved under this Agreement will not exceed **EIGHT HUNDRED THIRTY THOUSAND TWO HUNDRED TWENTY DOLLARS** (\$830,220.00) (the "Cap Amount") without an amendment to this Agreement, which encompasses the following orders, contingencies, and associated fees: (1) Order form #S-57966 in the amount of \$ \$476,291.66 , (2) Annual Support estimated for Year 2-5, in the amount of \$78,908.56, (3) Additional Hardware estimated , in the amount of \$200,000.00, (4) Taxes & Incidentals estimated, in the amount of \$60,000.00, and (5) Project Contingency in the amount of \$15,019.78.
- 3.2 **LICENSE FEES.** Licensee shall pay Philips Capsule the License fees set forth on an Order for any License(s) purchased hereunder. Unless otherwise set forth on an Order, License fees for any License(s) will be invoiced upon execution of this Agreement or Philips Capsule's acceptance of a subsequent Order for Licenses.
- 3.3 **ANNUAL SUPPORT FEES & RENEWAL.** Licensee shall pay Philips Capsule the fees set forth on an Order for the initial annual Support term. Unless otherwise set forth on an Order, the initial annual Support term fees will be invoiced upon the Support term start date as set forth in Section 5.1 (c). Support renewal fees are invoiced annually, 60 days in advance of the anniversary of the Support term start date. Annual Support fees may be increased by Philips Capsule annually by the Lesser of (i) 4% per year or (ii) the most recently published 12-month percent change in the United States consumer price index for medical care services (CPI-MCS) as of the renewal invoice date.
- 3.4 **HARDWARE FEES.** Licensee shall pay Philips Capsule the Hardware fees set forth on an Order. Individual per unit Hardware prices exclude shipping and handling costs; actual shipping and handling costs are prepaid by Philips Capsule and charged back to the Licensee and will be separately itemized on the related invoice. Unless otherwise set forth on an Order, Hardware fees and related shipping and handling costs will be invoiced upon delivery of the Hardware.
- 3.5 **PROFESSIONAL SERVICES FEES.** Licensee shall pay Philips Capsule the Professional Services fees agreed to by the parties in a Statement of Work (SOW) or an Order accepted by Philips Capsule. Unless otherwise set forth on an Order, Philips Capsule shall invoice Licensee for the actual Services Fees and related travel expenses incurred in a month, on a monthly basis, in arrears.
- 3.6 **TAXES.** All fees are exclusive of taxes, duties, levies and other similar charges. Licensee will be responsible for payment of all such taxes (other than taxes based on Philips Capsule's income or operations), arising from the delivery of services, sale of products or license of technology to Licensee, except to the extent Licensee is exempt from such taxes. Any such taxes required to be collected by Philips Capsule will be invoiced to Licensee unless Licensee provides Philips Capsule with satisfactory evidence of Licensee's exemption, as required in the form attached as Schedule H (subject to further verification at Philips Capsule's reasonable request).

3.7 **PAYMENT.** Payments will be made by check or bank transfer, within 45 days from the date of the invoice. If any undisputed amount is overdue and payment is not made within 10 days after written notice to Licensee, Philips Capsule may charge Licensee interest at the rate of 1.5% per month (or the highest amount permitted by law, whichever is lower) on the overdue amount. Invoices will be sent via email to: HS_HIT_AccountsPayable@smcgov.org.

3.8 **SUBSEQUENT ORDER LIMITS.** Licensee will not submit subsequent orders for amounts that exceed the Cap Amount.

4. **DELIVERY AND ACCEPTANCE**

Unless otherwise set forth below or in the applicable Order, the License for Philips Capsule Software listed on Schedule A will be deemed delivered and accepted upon execution of this Agreement. Unless otherwise set forth below or in the applicable Order, acceptance of subsequent Licenses or additional Philips Capsule Software products occurs upon Philips Capsule's acceptance of an Order for those Licenses or products.

4.1 **LICENSES SERVICE REQUIREMENTS**

(a) Upon execution of this Agreement, Licensee will be granted access to the customer portal on Philips Capsule's website so that Licensee can download the Philips Capsule Software and Documentation. The License for Philips Capsule Software listed on Schedule A will be deemed delivered and accepted upon execution of this Agreement. Acceptance of subsequent Licenses or additional Philips Capsule Software products occurs upon Philips Capsule's acceptance of an Order for those Licenses or products.

(b) Upon installation by Licensee, the Philips Capsule Software will generate a code. Licensee will use that code in Philips Capsule's automatic key generation tool to create the corresponding unique key ("Site Key"). Upon input of the Site Key, the Philips Capsule Software will be activated. A separate Site Key is required for each server on which the Philips Capsule Software is installed and for each new Philips Capsule Software product. Instructions for activation will be sent to the email address indicated in the "ship to" box on an Order, unless another email address is clearly identified on the Order for this purpose.

4.2 **HARDWARE.**

(a) Philips Capsule will ship Hardware FCA (Free Carrier) – Philips Capsule's U.S. logistics platform (FCA – Lockbourne, OH, USA, Incoterms 2010). If Licensee wishes Philips Capsule to arrange for shipment, freight will be prepaid by Philips Capsule and charged back; otherwise, Philips Capsule will arrange for shipment based upon Licensee's carrier account. Title and risk of loss to Hardware passes to Licensee upon being made available for pickup by the carrier. Unless otherwise specified in writing, the parties agree that client will take delivery of all hardware purchased on an Order within 12 months of the date of Order.

(b) Acceptance of Hardware occurs upon delivery to Licensee. Acceptance may be revoked by Licensee in writing within 30 days after delivery, based solely on (i) discrepancies between the Hardware received and Licensee's order, or (ii) any damage to the Hardware suffered prior to delivery. Claims made after such 30 day period or based on any other cause do not revoke acceptance but will be handled under the limited warranty in Section 7.2.

4.3 **PROFESSIONAL SERVICES AND IMPLEMENTATION.**

(a) Licensee is responsible for procuring, installing, configuring and maintaining the Medical Devices, hardware, software, computer network and communications services needed to run the Philips Capsule Software and Hardware.

- (b) Licensee is responsible for installing the Philips Capsule Software and Hardware components, physically connecting the Medical Devices, configuring the Philips Capsule Software, integrating the Philips Capsule Software to the medical software, and performing all necessary tests on the installation. Licensee may request that Philips Capsule assist with the implementation, but Licensee has responsibility for final testing and approval of the Philips Capsule Software and Hardware prior to use with patients.
- (c) In the event that Licensee wishes Philips Capsule to assist with implementation of the Philips Capsule Software license(s) purchased in Schedule A or a subsequent Order, the Professional Services will be agreed to by the parties in a Statement of Work (SOW). The SOW for the implementation of the initial software license(s) purchased in Schedule A is attached to this Agreement as Schedule F.

5. SUPPORT

5.1 SOFTWARE SUPPORT PROGRAM.

- (a) Philips Capsule's Support program for the Philips Capsule Software, including contact information, service levels and excluded services, is set forth in Schedule D. Support does not include maintenance or repair of Hardware. Terms of the Hardware warranty are set forth in Schedule E.
- (b) Upon execution of this Agreement, Licensee will be granted access to the customer portal on Philips Capsule's website so that Licensee can download Updates and DDIs and gain access to the knowledge base and other support tools available for the Philips Capsule Software.
- (c) Initial annual Support Term: Unless otherwise set forth on an Order, the annual Support term for the initial software purchase starts 90 days after the Effective Date. The annual Support term for subsequent License purchases starts upon Philips Capsule's acceptance of the Order for the additional Licenses. Unless otherwise agreed to in writing, the mandatory initial Annual Support term is 12 months in duration.
- (d) Support Renewal Term: Unless otherwise agreed to in writing, a Support Renewal Term shall be 12 months in duration and will be invoiced at the dates and fees as set forth in Section 3.3. As long as Philips Capsule offers support for the Philips Capsule Software version used by Licensee and Licensee has paid the applicable Support fees, Philips Capsule will provide Support to Licensee.

5.2 UPDATES AND UPGRADES. Any Updates or upgrades to the Philips Capsule Software are owned by Philips Capsule, even if made at the request of, or solely for the use of the Licensee, and may be made available to other Philips Capsule customers.

- (a) Updates: As long as Licensee has paid the applicable Support fees, Licensee will have access, at no additional charge, to any Update that Philips Capsule makes generally available.

5.3 DDIS.

- (a) As long as Licensee has paid the applicable Support fees, Licensee will have unlimited access to the DDI Library to download DDIs.
- (b) Upon Licensee's request, Philips Capsule will determine the feasibility of developing new DDIs. Development of DDIs is not part of Support and may be subject to payment of additional fees. Once developed and made available to Licensee, support of such DDIs will be covered by Support. New DDIs are owned by Philips Capsule and may be made available to other Philips Capsule customers as part of the DDI Library.

5.4 SUPPORT LAPSE AND REINSTATEMENT FEE.

- (a) Philips Capsule is not required to provide Support beyond the end of the applicable Support term.

- (b) If Licensee fails to order Support services for Philips Capsule Software purchased on Schedule A or a subsequent Order, or orders Support services but fails to pay the required support fee within the required payment period, Philips Capsule will apply reinstatement fees:
 - (i) The Reinstatement Fee: This fee is equal to the amount of the Support fee that should have been paid during the lapsed period ("Lapsed Support Fee"). The amount of the Lapsed Support Fee is determined by multiplying the Annual Support Fee as of the date of reinstatement, by the number of months that the Support services have expired ("Lapsed Period Ratio") and divided by twelve (12), and then multiplied by two (2). For a lapsed period which is not in whole months, the Lapsed Period Ratio can be prorated by the number of days in the month by which the support services have expired divided by the number of days in the respective month; Plus, The Annual Support Fee (as of the date of reinstatement) for the new Support Period.
- (c) Also, in circumstances where a Licensee has purchased Support and has failed to purchase a sufficient quantity of licenses to account for its actual usage of the Philips Capsule Software, in addition to paying all applicable additional license fees to account for the license shortfall, Licensee will be required to pay maintenance and Support reinstatement fees for the additional licenses necessary to rectify the shortfall. This reinstatement fee will be calculated based on the formula in Section 5.4(b)(i) above applying a minimum of two (2) years as the lapsed period.

6. INTELLECTUAL PROPERTY

6.1 OWNERSHIP.

- (a) Philips Capsule Software is licensed to, and not owned by the Licensee. Licensee acknowledges that the Philips Capsule Software, and the technology in the Hardware, is owned by and proprietary to Philips Capsule and Philips Capsule's suppliers, including all applicable rights to patents, copyrights, trade secrets and trademarks. The Philips Capsule Software is protected by United States and international copyright laws, as well as other laws related to the protection of rights in intellectual property. Philips Capsule shall at all times retain sole and exclusive ownership of the Philips Capsule Software (and all whole or partial copies thereof), including all intellectual property rights therein. Philips Capsule reserves all rights not specifically granted under this Agreement. Nothing in this Agreement shall be construed as granting Licensee any right or license to the Philips Capsule Software, or under any intellectual property right of Philips Capsule (including any rights Philips Capsule may have in any patents, copyrights, trademarks, service marks or any trade secrets), by implication, estoppel or otherwise, except as expressly set forth in this Agreement. Licensee shall not remove any copyright notices, patent markings, restricted right notices, restricted rights legends or other notices from the Philips Capsule Software or Hardware without prior written permission. Nothing herein will be construed to assign or transfer any intellectual property rights in the Philips Capsule Software or Hardware, or to license any rights other than as expressly set forth in this Agreement.
- (b) If Philips Capsule creates any Updates, upgrades or other new changes to the Philips Capsule Software or Hardware at Licensee's request, including but not limited to development of new software modules, Licensee shall not have or claim ownership of such changes which remain Philips Capsule's proprietary property.
- (c) Licensee shall not carry out reverse engineering on, decompile, disassemble, or otherwise attempt to discover or derive the source code or other underlying intellectual property of the Philips Capsule Software or Hardware. Licensee shall not create derivative works of the Philips Capsule Software or combine the Philips Capsule Software with other software.

- 6.2 TRADEMARK. Licensee shall not use the Philips Capsule trademarks, including but not limited to SMARTLINX, DATACAPTOR, NEURON, AXON, PHILIPS CAPSULE or BERNOULLI ONE or any other

trademarks, service marks or logos of Philips Capsule, in any manner or form and for any purpose that has not been approved in advance in writing by Philips Capsule.

- 6.3 **COPIES.** Licensee may make a reasonable number of copies of the Philips Capsule Software for testing, backup and archival purposes, provided that in no event may Licensee be running more copies of the Philips Capsule Software in production than it has paid for Licenses. Licensee shall not create copies or derivative works of the Documentation, including but not limited to the DDI help files, other than for its own internal use.
- 6.4 **SUBLICENSING.** Unless otherwise expressly agreed in advance in writing by Philips Capsule, Licensee shall not sublicense the Philips Capsule Software to a third party.
- 6.5 **AUDIT.** During the term of this Agreement and for five years after termination, Philips Capsule may audit Licensee's use of the Philips Capsule Software. Audits may be requested once in any 12 month period on ten days' advanced written notice. Licensee will cooperate with the audit, including by providing access to any books, computers, records or other information that relate to use of the Philips Capsule Software. Audits will take place during normal business hours and will not unreasonably interfere with Licensee's business activities. In the event an audit reveals unauthorized use of the Philips Capsule Software, Licensee will immediately correct such unauthorized use and reimburse Philips Capsule for the reasonable cost of the audit, in addition to such other rights and remedies as Philips Capsule may have.

7. **WARRANTY**

- 7.1 **PHILIPS CAPSULE SOFTWARE WARRANTY.** For Philips Capsule Software, Philips Capsule warrants for a period of 90 days from activation of the first Site Key or execution of this Agreement, as the case may be, that each Philips Capsule Software product will perform substantially in compliance with the then-current Documentation. Licensee's remedy for any material non-compliance with this warranty will be for Philips Capsule to modify, repair or replace the Philips Capsule Software to cure such non-compliance, or, if Philips Capsule cannot cure the non-compliance, Philips Capsule will refund the amount Licensee has paid for the non-compliant Philips Capsule Software and terminate this Agreement.
- 7.2 **HARDWARE WARRANTY.** Philips Capsule warrants for the period set forth in Schedule E from delivery to Licensee that the Hardware (i) is free of material defects in material and workmanship and will perform substantially in compliance with its Documentation, and (ii) is free and clear of all liens and encumbrances (other than those created or incurred by Licensee). Licensee's remedy for any material non-compliance will be for Philips Capsule to repair or replace the non-compliant Hardware to cure such non-compliance, or, if Philips Capsule cannot cure the non-compliance, Philips Capsule will refund the amount Licensee has paid for the non-compliant Hardware. This warranty is subject to the conditions and procedures set forth in Schedule E.
- 7.3 **PROFESSIONAL SERVICES WARRANTY.** Philips Capsule warrants for a period of 90 days after performance of a particular service that Support and any other services performed by Philips Capsule will be of professional quality conforming to generally accepted industry standards. Licensee's remedy in the event of any material non-compliance will be for Philips Capsule to re-perform the non-compliant services at no cost to Licensee or, if re-performance of the services is not feasible, Philips Capsule will refund the amount Licensee has paid for the non-compliant services.
- 7.4 Except as otherwise specifically provided herein, Philips Capsule does not warrant that the Philips Capsule Software will meet the requirements of Licensee or that operation of the Philips Capsule Software will be uninterrupted or error free. The remedies set forth in the warranties above state Philips Capsule's sole obligations with regarding the applicable warranty set forth in this Article 7.
- 7.5 **WARRANTY DISCLAIMER. EXCEPT FOR THE EXPRESS LIMITED WARRANTY SET FORTH IN THE SECTION ABOVE, THE PHILIPS CAPSULE SOFTWARE, SUPPORT AND SERVICES ARE PROVIDED "AS IS," WITHOUT WARRANTY OF ANY KIND, WHETHER EXPRESS, IMPLIED, OR ARISING BY CUSTOM, COURSE OF**

DEALING OR TRADE USAGE. WITHOUT LIMITING THE FOREGOING, PHILIPS CAPSULE SPECIFICALLY DISCLAIMS ANY IMPLIED WARRANTIES OF NON-INFRINGEMENT, MERCHANTABILITY, AND FITNESS FOR A PARTICULAR PURPOSE.

No terms, conditions, understandings or agreements purporting to modify the terms of these warranties shall have any legal effect unless made in writing and signed by an authorized officer of Philips Capsule.

8. INDEMNIFICATION AND INSURANCE

8.1 **INDEMNITY.** Each party (the "Indemnifying Party") hereby agrees to defend and indemnify the other party and its subsidiaries and affiliates, and their directors, officers, employees, agents and shareholders (each, an "Indemnified Party"), against third party claims, actions, demands, liabilities, losses, damages, judgments, settlements, costs and expenses (including reasonable attorneys' fees) (each, a "Claim"), to the extent such Claim results from (i) any infringement of copyright or trademark, or misappropriation of trade secrets, by the Philips Capsule Software or Hardware, when Philips Capsule is the Indemnifying Party (ii) any violation of Section 2.2 of this Agreement, when Licensee is the Indemnifying Party.

8.2 **MITIGATION.** If an infringement Claim is made against the Philips Capsule Software or Hardware, or Philips Capsule believes such a Claim may be made, Licensee will allow Philips Capsule to, at Philips Capsule's sole option and expense, (i) modify or replace the Philips Capsule Software or Hardware to cure the infringement, or (ii) obtain a license for Licensee to continue using the Philips Capsule Software or Hardware.

8.3 **PROCEDURE.** The Indemnified Party will give to the Indemnifying Party (i) written notice of any Claim as promptly as possible after its first knowledge thereof; (ii) sole control of the defense of any legal action; and (iii) such assistance, at the Indemnifying Party's expense, as it may reasonably request to defend or settle such claim. The Indemnified Party will not settle or compromise any Claim without the Indemnifying Party's express written consent. The Indemnifying Party will not settle any Claim without the Indemnified Party's express written consent unless such settlement completely releases the Indemnified Party and requires no admission of fault by the Indemnified Party. The Indemnified Party's material failure to comply with this Section or any delay in notice to the Indemnifying Party that materially prejudices its ability to defend a legal action will relieve the Indemnifying Party of its indemnification obligation under this Section.

8.4 INSURANCE

a. **GENERAL REQUIREMENTS** Philips Capsule shall obtain and maintain insurance for Licensee's benefit as described below. Philips Capsule shall furnish Licensee with certificates of insurance evidencing the required coverage, Philips Capsule's coverage to include the contractual liability assumed by Philips Capsule pursuant to this Agreement. Philips Capsule to provide that thirty (30) days' notice must be given, in writing, to Licensee of any pending change in the limits of liability or of any cancellation or modification of the policy.

b. **WORKERS' COMPENSATION AND EMPLOYER'S LIABILITY INSURANCE** Philips Capsule shall have in effect during the entire term of this Agreement workers' compensation and employer's liability insurance providing full statutory coverage. In signing this Agreement, PHILIPS CAPSULE certifies, as required by Section 1861 of the California Labor Code, that (a) it is aware of the provisions of Section 3700 of the California Labor Code, which require every employer to be insured against liability for workers' compensation or to undertake self-insurance in accordance with the provisions of the Labor Code, and (b) it will comply with such provisions before commencing the performance of work under this Agreement.

c. **LIABILITY INSURANCE** Philips Capsule shall take out and maintain during the term of this Agreement such bodily injury liability and property damage liability, cyber liability, and professional liability / errors & omissions insurance as shall protect Philips Capsule and all of its

employees/officers/agents while performing work or services covered by this Agreement from any and all claims for damages for bodily injury, including accidental death, as well as any and all claims for property damage or data theft and/or data loss which may arise from Philips Capsule's operations under this Agreement, whether such operations be by Philips Capsule, any subcontractor, anyone directly or indirectly employed by either of them, or an agent of either of them. Such insurance shall be primary, non-contributory combined single limit for each occurrence, , and shall not be limited, reduced, or otherwise affected by any limitations of liability in this Agreement and shall not be less than the amounts specified below:

Commercial General Liability.....	\$1,000,000
Cyber Liability.....	\$ 5,000,000
Professional Liability / Errors & Omissions	\$1,000,000

- d. Licensee and its officers, agents, employees, and servants shall be named as additional insured on the commercial general liability insurance under a blanket form endorsement, which shall also contain a provision that (a) the insurance afforded thereby to Licensee and its officers, agents, employees, and servants shall be primary insurance and (b) if the Licensee or its officers, agents, employees, and servants have other insurance against the loss covered by such a policy, such other insurance shall be excess insurance only.

In the event of the breach of any provision of this Section, or in the event any notice is received which indicates any required insurance coverage will be diminished or canceled, Licensee, at its option, may, notwithstanding any other provision of this Agreement to the contrary, immediately declare a material breach of this Agreement and suspend all further work and payment pursuant to this Agreement.

9. LIMITATION OF LIABILITY

9.1 **EXCLUSIONS.** Philips Capsule will not be liable for any Claims or other damages or losses to Licensee or any third party resulting from (a) modification of the Philips Capsule Software or Hardware without the express written consent of Philips Capsule, (b) use of the Philips Capsule Software or Hardware inconsistent with, or beyond the scope of, the Documentation, applicable laws or its intended use, (c) connection of the Philips Capsule Software or Hardware with unsupported, defective or misconfigured medical devices, hardware, software, computer network, power or communications services, (d) use of the Philips Capsule Software without an Update that would have prevented such claim (whether or not Licensee is paying for Support), (e) interruptions or errors in data or connectivity not caused or controlled by Philips Capsule, and (f) claims relating to any content, data, trademarks, logos or other branding provided by Licensee or third parties.

9.2 **LIMITATION.**

- (a) NEITHER PARTY WILL BE LIABLE FOR ANY INDIRECT, INCIDENTAL, SPECIAL, EXEMPLARY, RELIANCE, CONSEQUENTIAL OR PUNITIVE DAMAGES, OR ANY DAMAGES BASED ON LOST PROFITS OR SAVINGS, , COVER, LOSS OF BUSINESS OR BUSINESS INTERRUPTION. IN NO EVENT WILL EITHER PARTY BE LIABLE FOR ANY CLAIMS OR LIABILITIES, IN THE AGGREGATE EXCEEDING THE TOTAL OF 2x (TWO TIMES) THE AMOUNT OF FEES PAID TO PHILIPS CAPSULE UNDER THIS AGREEMENT.
- (b) These limitations will otherwise apply regardless of the form of action, whether based on contract, tort including negligence, statute or any other legal or equitable theory, even if a party has been advised of the possibility of such damages and even if a remedy has failed of its essential purpose. These limitations will be enforced to the fullest extent permitted by applicable law.

10. TERM AND TERMINATION

- 10.1 **TERM.** The initial term of this Agreement will be for a period of (60) months, commencing on June 25, 2024 and continuing through June 24, 2029, unless sooner canceled or terminated or amended in accordance with the provisions of this Agreement, (the "Initial Term").
- 10.2 The County of San Mateo will have the right to renew this Agreement after the Initial Term for an additional twelve (12) month period up to a maximum of two (2) renewal periods, subject to the terms and conditions in this Agreement (each a "Renewal Period," and together with the Initial Term, the "Term"). A renewal will be effective if evidenced by an amendment signed by the Parties.
- 10.3 **TERMINATION.** The Parties may terminate this Agreement and/or the Licenses set forth herein only as follows:
- (a) Either party may terminate this agreement at any time without a requirement of good cause upon thirty (30) days' advance written notice to the other party.
 - (b) Either party may terminate this Agreement and the Licenses if the other party breaches this Agreement, and such breach is not cured within thirty (30) days after receipt of written notice specifying the breach.
 - (c) Either party may terminate Agreement and the Licenses if the other parties' funding is unavailable from Federal, State, or County sources, insolvent, files or has filed against it a valid petition under applicable bankruptcy or insolvency laws, proposes any dissolution, composition, or financial reorganization with its creditors, makes an assignment for the benefit of creditors, or if a receiver, trustee, custodian or other similar agent is appointed and takes possession of all or substantially all of the other party's assets.
 - (d) Perpetual Licenses are not subject to termination except as set forth in Section 10.1(a) above and Section 10.1(e) below.
 - (e) Support is not perpetual and may be terminated (i) by Licensee at any time upon written notice to Philips Capsule, or (ii) by Philips Capsule for non-payment of fees 30 days after written notice to Licensee. Licensee will not be eligible for any refund of fees already paid. Termination of Support does not terminate the Agreement or the Licenses for Philips Capsule Software.
- 10.4 **EFFECT OF TERMINATION.** Termination of this Agreement will terminate all Licenses and will not relieve Licensee of its obligation to make any payment due prior to the effective date of termination. Except as otherwise set forth herein, Licensee is eligible for any refund of fees already paid for professional services defined in a Statement of Work but not yet completely rendered to Licensee as a result of termination of this Agreement or any License. Immediately upon termination of this Agreement or any License, Licensee will uninstall and destroy all copies of the Philips Capsule Software and Documentation and will certify such destruction to Philips Capsule in writing.
- 10.5 **SURVIVAL.** Sections 2.2, 3, 6, 7.4, 7.5, 8, 9, 10.2, 11, 12 and 13 will survive termination of this Agreement according to their terms, and such other provisions that so indicate or, by their nature should reasonably be presumed to survive termination or expiration of this Agreement.

11. CONFIDENTIALITY

- 11.1 **CONFIDENTIAL INFORMATION.** "Confidential Information" means any data or information regarding (a) the Philips Capsule Software and other Philips Capsule products, (b) either party's business operations that are not generally known to the public, including, but not limited to, information regarding products, services, suppliers, marketing strategies, finance, operations, customers, sales and internal performance results, (c) proprietary technology, including, but not limited to, concepts, designs, documentation, reports, data, specifications, user guides, software, databases, inventions, know-how and trade secrets, whether or not patentable or copyrightable,

and (d) any information designated by the disclosing party as “confidential” or “proprietary” or which, under the circumstances, would be reasonably considered to be confidential. Confidential Information does not include information that: (i) is a copy of this Agreement, its terms, and the price(s) charged by Philips Capsule to Licensee, (ii) is or becomes generally known or available by publication, commercial use or otherwise through no fault of the receiving party; (iii) is or becomes known to the receiving party without violation of any confidentiality restriction and without any restriction on the receiving party's further use or disclosure; or (iv) is independently developed by the receiving party without use of the disclosing party's Confidential Information.

11.2 **Public Records Act.** Philips Capsule recognizes that Licensee is a local governmental agency subject to the California Public Records Act ("PRA"), Government Code §§7920.000, et seq. Philips Capsule will work with Licensee to provide reasonably necessary information (e.g., a copy of the Agreement with Philips Capsule's Confidential Information redacted for Licensee's response to a PRA request) to facilitate Licensee's timely meeting Licensee's legal obligations with respect to any legally required disclosure. If requested pursuant to a PRA request to disclose the redacted copy of the Agreement referenced in the immediately preceding sentence or any documents which contain Philips Capsule's Confidential Information, Licensee will give Philips Capsule notice and a copy of such PRA request at least ten (10) days prior to the applicable statutory deadline to which Licensee are required to produce records responsive to such request so that Philips Capsule may review the requested records. Philips Capsule may request Licensee withhold, or redact those portions of, such records that Philips Capsule asserts are confidential or exempt from disclosure as provided under California law. Prior to any required disclosure, Licensee and Philips Capsule will discuss how Licensee are responding and Philips Capsule may seek a protective order, and Licensee will reasonably cooperate with Philips Capsule's efforts to protect any Philips Capsule Confidential Information against disclosure, provided that in no event will Licensee be required to initiate legal action to avoid the disclosure. If a requestor seeks to obtain the redacted information through a court proceeding, Licensee will promptly notify Philips Capsule allowing Philips Capsule reasonable time to oppose such request. If, after Philips Capsule receives notice in accordance with the preceding sentence, Licensee is required to disclose such information by court order, then Licensee may disclose such information pursuant to the requirements of the statute and such binding court order (except if Philips Capsule may seek a stay of such court order, then not until Philips Capsule's time to seek such stay has expired or the stay is finally denied). In the event that Philips Capsule does timely file with a court of law to seek a protective order, only following the final judgment in such action, or earlier with Philips Capsule's written consent or if Philips Capsule's time to obtain such protective order has expired, may Licensee disclose such information as required by law. In any court proceeding to restrict disclosure of Philips Capsule's Confidential Information pursuant to a PRA request, Philips Capsule will not unreasonably withhold its consent if Licensee seeks to excuse itself from such proceeding, provided such excusal does not limit Philips Capsule's ability to seek, assert, or enforce a protective order. Philips Capsule agrees to defend, indemnify, and hold Licensee harmless from any costs (including attorneys' fees) and damages claimed to be owed to the requestor under the PRA that are directly and proximately caused by Licensee not disclosing, at Philips Capsule's request, any document or portion thereof, to the extent such costs and damages are incurred during the period of beginning when Licensee refuse to disclose such document or portion thereof at Philips Capsule's request until the time that Philips Capsule directs Licensee to release such document or portion thereof (or, if Philips Capsule fails to do so, until such costs and damages otherwise cease to be incurred); provided, however, that (i) Licensee promptly notify Philips Capsule in writing of any PRA request or other attempt to compel production of such Philips Capsule's Confidential Information, promptly provide Philips Capsule with the information reasonably required for the defense of the same, and grant Philips Capsule exclusive control over the defense and settlement of the claim, and (ii) Licensee have not, without Philips Capsule's express written consent or a valid court order (except if Philips Capsule may seek a stay of such court order, then not until Philips Capsule's time to seek such stay has expired or the stay is finally denied), disclosed to any third party such Philips Capsule's Confidential Information that Philips Capsule has requested not to be disclosed.

11.3 **USE AND DISCLOSURE RESTRICTIONS.** Each party shall protect the other party's Confidential Information in its possession or control using the same degree of care that it uses to protect its own Confidential Information, which in no event shall be less than a reasonable degree of care. Neither party will use the other party's Confidential Information except for the purposes of performing or exercising rights under this Agreement or disclose such Confidential Information to any third party except to employees or contractors as is reasonably required in connection with the exercise of its rights and obligations under this Agreement (and only subject to disclosure restrictions at least as protective as those set forth herein). However, the receiving party may disclose the other party's Confidential Information: (a) pursuant to the order or requirements of a court, administrative agency or other governmental body, or as may be required by any law or regulation, provided that the receiving party gives reasonable notice to allow the disclosing party to contest such order or requirement (unless such notice is prohibited by law); and (b) on a confidential basis to legal and financial advisors. The receiving party will return, or at the disclosing party's option, destroy (with certification of destruction), any Confidential Information in its possession upon termination of this Agreement for any reason.

12. **COMPLIANCE WITH LAWS**

12.1 **GENERAL COMPLIANCE REQUIREMENT.** Each party will comply with all applicable federal, state and local laws and regulations relating to its activities under this Agreement.

12.2 **MEDICARE/MEDICAID.** Each party represents that (a) it is not excluded from participation under any federal health care program for the provision of items or services for which payment may be made under a federal health care program, and (b) it has not knowingly or negligently employed or contracted with a person or entity that is excluded from participation in any federal health care program.

12.3 **BUSINESS ASSOCIATE ADDENDUM.** Because Philips Capsule may observe or have access to PHI as part of implementation or Support services, or through certain Philips Capsule Software products, Philips Capsule acknowledges that it may be considered a "business associate" under the Health Insurance Portability and Accountability Act of 1996 and the regulations promulgated thereunder ("HIPAA") and agrees to comply with the applicable provisions of HIPAA, HITECH and related regulations, including those obligations set forth in the Business Associate Addendum attached as Schedule G to this Agreement and incorporated herein by this reference, to the extent applicable. Philips Capsule may store and de-identify the data collected or transmitted by the Philips Capsule Software for the purpose of monitoring Philips Capsule system performance, bench marking, development of Philips Capsule analytics for use in the Philips Capsule system.. All such data shall be de-identified in accordance with HIPAA so long as Philips Capsule keeps such data in de-identified form and makes no effort to re-identify the data. Any Philips Capsule use of de-identified data in any method, depiction, program, schematic, algorithm, or design to improve system performance, bench marking, or development of analytics will be Philips Capsule's proprietary confidential information. Notwithstanding Sections 8 (entitled **INDEMNIFICATION**), Section 9 (entitled **LIMITATION OF LIABILITY**) and each Section's respective subparts, above, Philips Capsule will indemnify and hold Licensee harmless from any loss, damage, cost, judgment, or award only to the extent that it is found by a final trial court judgment that Philips Capsule's breach of the Business Associate Addendum attached as Exhibit G has caused such loss, damage, cost, judgment or award.

12.4 **EQUAL OPPORTUNITY.** Philips Capsule agrees to comply with all applicable equal opportunity laws.

12.5 **ANTI-CORRUPTION COMPLIANCE.** The parties agree that, in connection with the transactions contemplated by the Agreement or in connection with any other business transactions involving Philips Capsule, the parties, and everyone acting on the parties' behalf, will comply with and will not violate any anti-corruption law or international anti-corruption standards, including but not limited to the U.S. Foreign Corrupt Practices Act.

- 12.6 **EXPORT LAWS.** The parties acknowledge that the Philips Capsule Products and any other hardware, software, source code and technology obtained from Philips Capsule are subject to the U.S. government export control and economic sanctions laws.
- 12.7 **REGULATORY COMPLIANCE.** Philips Capsule is responsible for all applicable regulatory compliance with respect to the manufacture, distribution and Support Services for Philips Capsule products.

Reporting for Philips Capsule Products

- (a) Licensee shall immediately notify Philips Capsule of (i) any adverse patient event complaint relating in any way to the functions of Philips Capsule Products and (ii) of any other incident of which Licensee in its reasonable estimation believes it should inform Philips Capsule.
- (b) Incidents that require reporting are: (i) incidents that Philips Capsule products contributed to or caused a death or serious injury and (ii) incidents where Philips Capsule products has malfunctioned and, if that malfunction occurred again, would be likely to contribute or cause a death or serious injury. As used herein, "Serious Injury" means: Any injury or illness that (i) is life threatening; (ii) results in permanent impairment of a body function or permanent damage to a body structure or (iii) necessitates medical or surgical intervention to preclude permanent impairment of a body function or permanent damage to a body structure.

13. GENERAL

- 13.1 **SEVERABILITY; WAIVER.** The provisions of this Agreement will be deemed severable, and the invalidity or unenforceability of any one or more of its provisions will not affect the validity or enforceability of any other provisions. If any provision of this Agreement is finally declared by a court of competent jurisdiction to be invalid or unenforceable for any reason, the parties will substitute a valid and enforceable provision that, to the maximum extent possible in accordance with applicable law, preserves the economic positions and original intentions of the parties. The waiver or failure of either party to exercise any right provided for herein will not be deemed a waiver of any further right hereunder.
- 13.2 **ASSIGNMENT.** This Agreement will be binding upon and will inure to the benefit of the parties hereto and their respective successors and permitted assigns. A party may not assign, sell or otherwise transfer this Agreement or any License without the prior written consent of the other party, unless: (i) the transfer is to a successor by way of merger or reorganization, or as part of a transfer of all or substantially all of the transferor's assets, and (ii) the transferee has agreed in writing to assume and perform all obligations of transferor under this Agreement. Notwithstanding such a transfer, transferor will remain liable for all obligations arising under this Agreement prior to the transfer.
- 13.3 **INDEPENDENT CONTRACTORS.** Philips Capsule and Licensee are independent contractors with respect to each other. Nothing in this Agreement will be deemed to constitute the parties as partners, joint ventures, principal/agent or employer/employee. Neither party will have any authority to act or represent itself as an agent of the other or in any manner to assume or create any obligation on behalf of or in the name of the other.
- 13.4 **NO THIRD PARTY BENEFICIARIES.** Nothing express or implied in this Agreement is intended or will be deemed to confer any rights, obligations, remedies or liabilities upon any person other than the parties and their respective successors and permitted assigns.
- 13.5 **FORCE MAJEURE.** Neither party hereto will be liable for any delay or failure in performance under this Agreement, excluding Licensee's obligation to pay fees due, resulting directly or indirectly from acts of God or any other causes beyond the reasonable control of such party.
- 13.6 **PUBLICATION.** Philips Capsule may include Licensee on its customer reference list and include names of devices and of information systems that are interfaced through this Agreement. Any other public disclosure regarding this Agreement will require the other party's prior approval.

13.7 **NOTICE.** Any notice provided pursuant to this Agreement will be in writing and will be addressed to the parties as indicated below. Notices will be effective when actually received in paper form by the contact person, except that a notice sent by courier or by overnight, certified or registered mail, postage prepaid, return receipt or signature confirmation requested, will be effective on the date the notice was accepted, refused or returned undeliverable. Email addresses are provided for convenience only; delivery of notice by email will not be deemed effective even if actually received. Either party may change its address by giving notice of the new address to the other party.

Philips Capsule:

CapsuleTech, Inc.
Attn: Legal Department
222 Jacobs Street
Cambridge, MA 02141
Fax: (978) 475-2980
Email: notice@capsuletech.com

Licensee:

County of San Mateo / County Health / Health Information Division
Thomas Collins, Director, Portfolio and Program Management
801 Gateway
South San Francisco, CA 94080
Email: tcollins@smcgov.org

With a copy to:
County Attorney's Office
400 County Center, 6th Floor
Redwood City, CA 94063
Facsimile: 650/363-4034

13.8 **GOVERNING LAW AND DISPUTE RESOLUTION.** This Agreement will be governed by and construed in accordance with the laws of California, excluding its choice of law rules. The parties agree that the following will not apply to this Agreement or to any transaction or relationship arising out of it: (i) UN Convention on Contracts for the International Sale of Goods, (ii) Uniform Computer Information Transactions Act, or (iii) American Law Institute Principles of the Law of Software Contracts.

13.9 **REPRESENTATION BY COUNSEL; NO INDUCEMENT.** Each party has had the opportunity to be represented by counsel of its choice in negotiating this Agreement. This Agreement will therefore be deemed to have been negotiated and prepared at the joint request, direction and construction of the parties, at arms' length, with the advice and participation of counsel, and will be interpreted in accordance with its terms without favor to either party. In entering into this Agreement, neither party is relying on, or has been induced by, any statement or omission of the other (or the other party's agents or employees) unless expressly contained in this Agreement. Each party waives any claim that some statement or omission, known or unknown, by the other (or the other party's agents or employees) wrongfully induced them to enter into this Agreement unless expressly contained in this Agreement.

13.10 **SOFTWARE AS A COMMERCIAL ITEM.** The Philips Capsule Software is a "commercial item" as that term is defined in 48 C.F.R. §2.101 (October 1995) consisting of "commercial computer software" and "commercial computer software documentation" as such terms are used in 48 C.F.R. §227.7202-1, 227.7202-3 and 227.7202-4 (June 1995). If the Licensee hereunder is the U.S. Government or any agency or department thereof, the Philips Capsule Software is licensed hereunder (i) only as a commercial item and (ii) with only those rights as are granted to all other users pursuant to the terms and conditions of this Agreement.

- 13.11 **ENTIRE AGREEMENT; CONSTRUCTION.** This Agreement, including the schedules attached hereto, constitutes the complete and exclusive statement of the terms and conditions between the parties, which supersedes and merges all prior and contemporaneous proposals, understandings and all other agreements, oral and written, between the parties relating to the subject matter of this Agreement. In the event of a conflict between the body of this Agreement and any schedule, the priority of such terms will be as follows: Schedule J, the body of the Agreement, all other Schedules. This Agreement may not be modified or altered, including by any click-through agreement, vendor registration process or pre-printed terms on a purchase order or invoice, except by written instrument signed by authorized persons from both parties specifically referencing this Agreement. Notwithstanding the foregoing, certain third-party software may be included with the Philips Capsule Software that is subject to its own license terms, which are included or referenced in the Documentation.
14. **SIGNATURE.** The execution and delivery of this Agreement has been duly authorized and constitutes the legal, valid and binding obligation on each of the parties. This Agreement may be executed and transmitted by facsimile or electronic mail in pdf or other electronic format, and in two or more counterparts, each of which shall be deemed an original and all of which together shall constitute one and the same instrument. A signature transmitted by facsimile or electronic mail shall be deemed an original signature for the purpose of this Agreement.

* * *

CapsuleTech, Inc

John McHutcheon

Electronically signed by: John
McHutcheon
Reason: "I Approve"
Date: May 27, 2024 17:32 EDT

May 27, 2024

John McHutcheon

CapsuleTech, Inc. Signature

Date

CapsuleTech, Inc. Name (please print)

COUNTY OF SAN MATEO

By:

President, Board of Supervisors, San Mateo County

Date:

ATTEST:

By:

Clerk of Said Board

SCHEDULES:

SCHEDULE A – ORDER

SCHEDULE B – LICENSES

SCHEDULE C – INTENDED USE STATEMENTS

SCHEDULE D – SUPPORT

SCHEDULE E – HARDWARE WARRANTY

SCHEDULE F – SOW

SCHEDULE G – BUSINESS ASSOCIATE ADDENDUM

SCHEDULE H – TAX EXEMPT STATUS

SCHEDULE I – FACILITIES



Schedule A

Opportunity #: S-57966
Date: 5/23/2024

Bill to:
County of San Mateo
801 Gateway Blvd.
2nd Floor (HLT416)
South San Francisco, California 94080
United States
Contact: Thomas Collins
Phone:
Email: tcollins@smcgov.org

Ship to:
San Mateo Medical Center (AKA San Mateo County Health System)
222 W. 39th Avenue
San Mateo, California 94403
United States
Contact: Thomas Collins
Phone:
Email tcollins@smcgov.org

The products and services listed on this Quote, and the products and services listed on any purchase order submitted by the customer in response to this quote, are governed by the terms and conditions of the Medical Device Information Platform Agreement (or predecessor DataCaptor agreement) executed by CapsuleTech, Inc. and the customer, and as may have been amended by the parties. For the avoidance of doubt, any other terms and conditions contained or referenced in the customer's purchase order do not apply. All products and services listed on this Quote must be delivered within 15 months of Order. This quote expires on 6/28/2024.

Software

Qty.	Part Number	Description	Selling Price	Amount
69.00	LICENT1	Facility Connectivity License	USD 1,173.00	USD 80,937.00
69.00	• MDIP-HA	MDIP High Availability License	Included	USD 0.00
1.00	MAINT1Y	Standard Maintenance Agreement - One Year	USD 14,568.66	USD 14,568.66
Software TOTAL:				USD 95,505.66

Hardware

Qty.	Part Number	Description	Selling Price	Amount
55.00	SL-NU3-UMPC-IOM4S2U	SmartLinx Neuron 3 with the 4 Serial + 2 USB Ports Connectivity Module Neuron3 requires 11.2.1 or higher Capsule Software version. Consequently, it may require a server upgrade.	USD 2,669.00	USD 146,795.00
59.00	SL-DIM-HW	SmartLinx Device Identification Module	USD 107.00	USD 6,313.00
59.00	B1-CPAT-DIM-14	DIM Patch Cable 14'	USD 21.00	USD 1,239.00
59.00	B1-XXX	Device Serial Cable (Generic)	USD 121.00	USD 7,139.00
60.00	NU3-CX-UPGRADE	Neuron3 Chart Xpress Upgrade w/ Generic Pole Mount & Cable Set	USD 2,667.00	USD 160,020.00
60.00	• SL-NU3-UMPC-IOCOVER	SmartLinx Neuron 3 (with Port Cover) Neuron3 requires 11.2.1 or higher Capsule Software version. Consequently, it may require a server upgrade.	Included	USD 0.00
60.00	• SL-NU3-DUBAT-KIT	SmartLinx Neuron 3 - Dual Battery Dock Kit	Included	USD 0.00
60.00	• SL-NU2-DUBAT	Capsule Neuron - Dual Battery Dock	Included	USD 0.00
60.00	• SL-NU3-DUBATMOUNT-XX	SmartLinx Neuron 3 - Dual Battery Dock: Generic Mount	Included	USD 0.00
60.00	• DC-NU2-EXTBAT	SmartLinx Neuron2 - External Battery	Included	USD 0.00
60.00	• CS-MOUNT-XXX	Mounting Solution (Generic)	Included	USD 0.00
60.00	• SL-DIM-HW	SmartLinx Device Identification Module	Included	USD 0.00
60.00	• B1-CPAT-XXX	Patch Cable (Generic)	Included	USD 0.00
60.00	• B1-XXX	Device Serial Cable (Generic)	Included	USD 0.00
Hardware TOTAL:				USD 321,506.00

Professional Services

Qty.	Part Number	Description	Selling Price	Amount
60.00	CONSULTH-PM	Consulting Hour(s) - Project Manager	USD 248.00	USD 14,880.00
160.00	CONSULTH-TC	Consulting Hour(s) - Technical Consultant	USD 215.00	USD 34,400.00
1.00	PROJECT-EXP	Travel & Expenses	USD 10,000.00	USD 10,000.00
Professional Services TOTAL:				USD 59,280.00

Sub-Total: USD 476,291.66
Tax:
Shipping:
Total: USD 476,291.66

Invoicing Terms:

Capsule Representative
Jonathan GIRSCH, jonathan.girsch@philips.com
Q-18294-1

CapsuleTech, Inc.
222 Jacobs Street, Cambridge, Massachusetts 02141 United States
Phone: (978)-482-2300 | www.capsuletech.com



For applicable products ordered:

Software: 100% on order
Maintenance: 100% on order
Hardware: 100% on delivery
Professional services: Monthly as delivered. Travel & Expenses invoiced as incurred

Customer

Signature: _____

Full Name: _____

Title: _____

Date: ____/____/____

Thank you for your business
(Please Attach Customer's Purchase Order to Sales Order)

SCHEDULE B

LICENSES

Philips Capsule markets the following types of licenses.

PHILIPS CAPSULE – PERPETUAL LICENSES

Philips Capsule offers the following software products, which are licensed perpetually, subject to the terms of the Agreement. Each product must be set forth in an Order.

- Philips Capsule MDI Connectivity
- Philips Capsule Advanced Integration

The Philips Capsule Licenses are priced per named bed in the designated location – regardless of whether and when these beds will use the license. The one exception to the named bed requirement is for the Philips Capsule Facility Connectivity License, which enables the collection of data from an unlimited number of medical devices per bed, for all licenses beds in the End User's named facility as of the effective date of the license. This license also includes non-bed instances such as the emergency, pre-op, OR, and PACU departments. Pricing is done on a per bed license for all beds in the designated facility – regardless of if/when these beds will use the license. If any outpatient facilities (including but not limited to urgent care centers) are to be included in the integration scope, those locations need to be included in the total license count. The number of licensed beds within the same named facility is allowed to be increased up to 10% without an additional fee, after which Philips Capsule has the right to ask for a fee payment of all additional beds. Customers are not authorized to transfer the licenses between facilities.

SCHEDULE C

INTENDED USE STATEMENTS

The following intended use statements govern certain Philips Capsule Hardware and Philips Capsule Software. The Hardware or Software that Licensee orders will be set forth in an Order.

Philips Capsule Medical Device Information Platform (CMDIP)

The Philips Capsule Medical Device Information Platform (CMDIP) is intended to transfer, store, and convert medical device data for use by medical devices and healthcare information systems, including those that provide clinical monitoring of a patient intended to be relied upon in deciding to take immediate clinical action. The CMDIP does not control or alter the function of any of the medical devices or information systems by or through which data are captured or consumed.

Please review the intended use statements provided in the accompanying documents delivered with the additional Philips Capsule products(s) Licensee is using.

SCHEDULE D

SUPPORT

1. Scope of Support.

- (a) Support is available for the current and two previous major releases (e.g., versions 6.x and 7.x when the current release is version 8.x) of the Philips Capsule Software, up to a maximum of three years from the general availability release of each major version.
- (b) Support is available on a 24 x 7 basis.
- (c) Support will be provided remotely, which includes telephone, email and Philips Capsule's customer portal (to download Updates and access the Support knowledge base). If needed, with Licensee's permission, Philips Capsule may use remote access to an on-site installation through WebEx or another mutually agreeable equivalent that does not require on-site access by Philips Capsule.
- (d) On-site Support will be provided only if Philips Capsule determines it cannot resolve an issue remotely, in which case Philips Capsule will come on-site without charge to Licensee.
- (e) Support does not include:
 - (i) On-site maintenance or support (except as stated above).
 - (ii) Philips Capsule Hardware or any third party products or services.
 - (iii) Errors resulting from use of the Philips Capsule Software contrary to the Documentation (such as use with unsupported software or hardware), abuse, willful destruction or failure to install an Update provided by Philips Capsule.
 - (iv) Removal of errors due to modifications or attempted servicing by any party other than Philips Capsule.

1. Conditions of Support.

- a) Licensee will designate one or more named Philips Capsule Software systems administrators who will maintain the system configuration, install drivers and perform upgrades as needed, administer back-ups and replace hardware. The System Administrators will function as the primary support contacts for Philips Capsule.
- b) Licensee will communicate with Philips Capsule for Support Services solely through Philips Capsule's technical support helpdesk at support@CapsuleTech.com or other address provided by Philips Capsule. Level 1 or 2 Errors may be reported by phone at 800-260-9537.
- c) Updates will be provided to Licensee via download from Philips Capsule's website.

- 2. **Billable Support.** Requests for (i) assistance concerning problems with the operation of third party hardware or software, (ii) modification, customization or enhancement of the Philips Capsule Software, or (iii) other services not included in Support pursuant to Section 1 above, will be billed at Philips Capsule's then-current rates. Philips Capsule and Licensee will agree in advance prior to any billable services being provided.

3. Licensee Responsibilities.

- a) Licensee will log in to the Philips Capsule customer portal on a regular basis in order to obtain the most recent Updates, Documentation and other current information concerning Philips Capsule Products. Philips Capsule recommends logging in at least once a month and installing the most current Updates.
- b) Licensee will provide Philips Capsule with all the means and information reasonably required to facilitate Philips Capsule's Support, including but not limited to providing Philips Capsule

with remote access to the Philips Capsule Software installation, if needed, and assisting in on-site troubleshooting.

- c) Licensee is responsible for implementing a standard backup policy to ensure the backup of all data, files and programs in order to prevent any loss, destruction or alteration of such work.

4. Service Levels.

- (a) Level of Priority. A level of priority will be assigned by Philips Capsule for each support request received by the helpdesk based on the following criteria:

INCIDENT DESCRIPTION	RESPONSE PRIORITY
Licensee reports an Error that causes critical system components to be down interrupting business continuity. *Production Environment only	Critical = 1
Licensee reports an Error that prevents users from performing routine daily tasks. *Test or Production Environments	High = 2
Licensee reports an Error that affects non-critical components or causes some annoyance but does not affect productivity. *Test or Production Environments	Medium = 3
Licensee reports an issue creating minor annoyance or cosmetic defect. *Test or Production Environments	Low = 4

If a temporary workaround exists, the Error will be assigned to the next lower priority level.

- (b) Response Time.

	PRIORITY 1	PRIORITY 2	PRIORITY 3	PRIORITY 4
Initial Response	1 Hour	2 Hours	12 Hours	Next Business Day
Status Update Frequency	Daily	Every Days ²	Monthly	Upon Request
Objective Resolution for	3 Days	10 Days	Next Release	At Philips Capsule's Discretion

- (c) Response.

- i. (Once Philips Capsule has determined that the issue is caused by the Philips Capsule Software, Philips Capsule will make reasonable efforts to determine the root cause and resolve the Error. The resolution timeframe provided above states Philips Capsule's objective for (A) resolving the Error, (B) providing a correction, or (C) providing a workaround. If a permanent resolution cannot be delivered within the timeframe, Philips Capsule will provide a work plan for resolving the Error and will execute upon that work plan.
- ii. Licensee understands that certain portions of the Philips Capsule Software are subject to FDA or other regulatory compliance requirements and that no software correction can be implemented in a production environment until it has passed Philips Capsule's validation process. The timeframe to resolve an issue will depend not only on the issue itself, but also on the time required to perform an appropriate validation.

Escalation. If Licensee does not receive the initial response, status update or resolution within the timeframes set forth in 5(b), or otherwise has a Support issue that is not resolved within a reasonable time within normal channels, Licensee may escalate to the next higher Philips Capsule employee listed below.

POSITION	NAME	CONTACT DETAILS
General Support		support@capsuletech.com 800-260-9537
Sr. Manager, Technical Support	Jody Bregler	Jody.Bregler@Philips.com 978-482-2312
VP, Professional Services	John McHutcheon	John.McHutcheon@Philips.com 978-482-2308

SCHEDULE E

The Warranty Terms below apply to Philips Capsule Hardware purchased starting from July 2016. Hardware purchased prior to that time is governed by the warranty in effect at the time of sale.

	Standard Warranty Duration	Extended Warranty Duration, if purchased (within 12 months of order issuance)
SmartLinx Axon 110, 410, 810	<ul style="list-style-type: none"> 1 year 	<ul style="list-style-type: none"> Up to 5 years total (4 years beyond Standard Warranty)
Philips Axon 120, 420, 421, 820	<ul style="list-style-type: none"> 1 year 	<ul style="list-style-type: none"> Up to 5 years total (4 years beyond Standard Warranty)
SmartLinx Device Identification Module	<ul style="list-style-type: none"> 1 year 	<ul style="list-style-type: none"> None
Cables (<i>serial and patch</i>), power cords, power supplies	<ul style="list-style-type: none"> 1 year 	<ul style="list-style-type: none"> None
Mounting solutions (<i>wall mounts or extended poles</i>)	<ul style="list-style-type: none"> 1 year 	<ul style="list-style-type: none"> None
Refurbished SmartLinx Neuron 2	<ul style="list-style-type: none"> 2 years for device 1 year for batteries (internal or external) 	<ul style="list-style-type: none"> None
SmartLinx Neuron 3	<ul style="list-style-type: none"> 2 years for device 1 year for batteries (internal or external) 	<ul style="list-style-type: none"> Up to 5 years total (3 years beyond Standard Warranty) for device None for batteries
SmartLinx Neuron 3 Connectivity Modules	<ul style="list-style-type: none"> 2 years for device 	<ul style="list-style-type: none"> Up to 5 years total (3 years beyond Standard Warranty) for device
SmartLinx Dual Battery Dock	<ul style="list-style-type: none"> 2 years (not including batteries) 	<ul style="list-style-type: none"> Up to 5 years total (3 years beyond Standard Warranty)
SmartLinx Standalone Dual EXTBAT AC Charger	<ul style="list-style-type: none"> 2 years (not including batteries) 	<ul style="list-style-type: none"> Up to 5 years total (3 years beyond Standard Warranty)
SmartLinx NIBP Module & SunTech Accessories (<i>on Neuron 2</i>)	<ul style="list-style-type: none"> 2 years for NIBP module 2 years for connector cover 2 years for OPD reusable cuffs 1 year for 3M hose No warranty for disposables and vinyl cuffs (however, Philips Capsule will replace if the product is damaged during transport to Licensee) 	<ul style="list-style-type: none"> Up to 5 years total (3 years beyond Standard Warranty) for NIBP module and connector cover None for other accessories
SmartLinx Alarm Hub	<ul style="list-style-type: none"> 2 years 	<ul style="list-style-type: none"> Up to 5 years total (3 years beyond Standard Warranty)

SmartLinx NIBP Monitoring Module & SunTech Accessories (on Neuron 2)	<ul style="list-style-type: none"> ▪ 2 years for NIBP Monitoring module ▪ 2 years for connector cover ▪ 2 years for OPD reusable cuffs ▪ 1 year for 3M hose ▪ No warranty for disposables and vinyl cuffs (however, Philips Capsule will replace if the product is damaged during transport to Licensee)) 	<ul style="list-style-type: none"> ▪ Up to 5 years total (3 years beyond Standard Warranty) for NIBP Monitoring module and connector cover ▪ None for other accessories
Philips Capsule NIBP Monitoring Module & SunTech Accessories (on Neuron 3)	<ul style="list-style-type: none"> ▪ 2 years for NIBP Monitoring module ▪ 2 years for connector cover ▪ 2 years for OPD reusable cuffs ▪ 1 year for 3M hose ▪ No warranty for disposables and vinyl cuffs (however, Philips Capsule will replace if the product is damaged during transport to Licensee)) 	<ul style="list-style-type: none"> ▪ Up to 5 years total (3 years beyond Standard Warranty) for NIBP Monitoring module and connector cover ▪ None for other accessories
Masimo SET Pulse Oximeter & Accessories	<ul style="list-style-type: none"> ▪ 2 years for uSpO2 pulse oximetry module ▪ 2 years for USB locking mechanism and ferrite ▪ 6 months for reusable sensors ▪ No warranty for single-use adhesive sensors (however, Philips Capsule will replace if the product is damaged during transport to Licensee) 	<ul style="list-style-type: none"> ▪ Up to 5 years total (3 years beyond Standard Warranty) for uSpO2 pulse oximetry module, USB locking mechanism and ferrite ▪ None for other accessories
Nellcor Oximeter & Accessories	<ul style="list-style-type: none"> ▪ 2 years for Nellcor oximetry module ▪ 6 months for Nellcor oximetry cable ▪ 6 months for reusable sensors ▪ No warranty for single-use sensors (however, Philips Capsule will replace if the product is damaged during transport to Licensee) 	<ul style="list-style-type: none"> ▪ Up to 5 years total (3 years beyond Standard Warranty) for Nellcor oximetry module ▪ None for other accessories
Exergen TAT-5000S Temperature Scanner & Accessories	<ul style="list-style-type: none"> ▪ Lifetime for scanner (but 5 years for the scanner cable) ▪ No warranty for single-use disposable caps and sheaths (however, Philips Capsule will replace if the product is damaged during transport to Licensee) 	<ul style="list-style-type: none"> ▪ None
Filac 3000 Temperature Module & Accessories	<ul style="list-style-type: none"> ▪ 2 years for Filac 3000 Temperature module ▪ 2 years for calibration plug ▪ 6 months for probes and isolation chambers ▪ No warranty for probe covers (however, Philips Capsule will replace if the product is damaged during transport to Licensee) 	<ul style="list-style-type: none"> ▪ Up to 5 years total (3 years beyond Standard Warranty) for Filac 3000 Temperature module ▪ None for other accessories

Masimo ISA Capnography module & Accessories	<ul style="list-style-type: none"> ▪ 2 years for Masimo ISA Capnography module ▪ 2 years for Mobility Kit ▪ 1 year for mounting bracket, mounting holder, maintenance kit and gas regulatory kit ▪ No warranty for the Masimo Nomolines (however, Philips Capsule will replace if the product is damaged during transport to Licensee) 	<ul style="list-style-type: none"> ▪ Up to 5 years total (3 years beyond Standard Warranty) for Masimo ISA Capnography module and Mobility Kit ▪ None for other accessories
Barcode Scanner	<ul style="list-style-type: none"> ▪ 5 years for barcode scanner ▪ 1 year for barcode scanner cable 	<ul style="list-style-type: none"> ▪ None
Roll Stand	<ul style="list-style-type: none"> ▪ 5 years 	<ul style="list-style-type: none"> ▪ None
Proximity Card Reader Kit (125KHz, 13.56MHz)	<ul style="list-style-type: none"> ▪ 1 year 	<ul style="list-style-type: none"> ▪ None
Pagers	<ul style="list-style-type: none"> ▪ 1 year 	<ul style="list-style-type: none"> ▪ None
Paging System	<ul style="list-style-type: none"> ▪ 1 year 	<ul style="list-style-type: none"> ▪ None
Workstations	<ul style="list-style-type: none"> ▪ 1 year for Monitor, PC and keyboard 	<ul style="list-style-type: none"> ▪ None
Perle Hubs	<ul style="list-style-type: none"> ▪ 1 year 	<ul style="list-style-type: none"> ▪ None
TERMS		
Warranty Includes	Hardware and accessories purchased directly from Philips Capsule. Defects in materials or workmanship under normal use during the warranty period which begins upon delivery of the product.	
Warranty Excludes	<ul style="list-style-type: none"> • Hardware found to be defective after expiration of the warranty period. • Hardware that Philips Capsule reasonably determines was misused, abused, mishandled, modified or altered in any way. • Hardware damaged by liquid. • Hardware that was lost, stolen or damaged due to a natural disaster or other hazard such as fire, lightning strike, flood, etc. • Cracked screens (unless crack was present at delivery). • Degraded battery performance from routine use and charging cycles. Due to the consumable nature of batteries and standalone power supplies, the Extended Warranty does not cover these components, even if an extended warranty has been purchased. • Hardware damaged by third party hardware, software, accessories, computer network, power or communications services. <p>Philips Capsule does not warrant that third-party-embedded software will be error free. Philips Capsule will use commercially reasonable efforts to address such errors.</p>	
Extended Warranty Purchase	The Philips Capsule Hardware Extended Warranty may be purchased only at the order issuance or within 12 months after the order issuance. To purchase	

	<p>the Extended Warranty, Licensee must purchase the Extended Warranty for all units of the same type of Philips Capsule hardware that were purchased on the same order.</p> <p>The fees for the Philips Capsule Hardware Extended Warranty will be invoiced upon delivery of the products, or upon order of the Extended Warranty if purchased after the date of product delivery. Extended warranty fees are non-refundable and cannot be transferred to other products.</p>
Remedy	<p>Defective products that are covered by an in force Philips Capsule Warranty will be replaced with new, refurbished or equivalent products at Philips Capsule's discretion. Philips Capsule does not offer repair services.</p> <p>Replacement products will be the same or newer versions, with the same or greater functionality than the original.</p> <p>Replacement products will be covered by Philips Capsule Warranty for the longer of 90 days from delivery or the remainder of the existing warranty period.</p>
RMA Process	<p>To initiate a return for warranty replacement, swap, repair or credit, Licensee must follow the Philips Capsule RMA Instructions provided on Philips Capsule Customer Portal, or available by contacting Philips Capsule Customer Service. The Philips Capsule RMA Instructions contain additional details and restrictions.</p>
Updated Warranty Terms	<p>All changes to Hardware Warranty are accessible on Philips Capsule Customer Portal.</p>

County of San Mateo

Capsule Philips MDI and Chart Express

STATEMENT OF WORK -**SCHEDULE F**

14 May 2024

Sales Manager: J Girsch

Prepared by: David Fishbough

Version: v3.5 – PS Approved

SO No.: S-57966

MEDICAL DEVICE INTEGRATION – STATEMENT OF WORK

This Statement of Work (“SOW”) is between **County of San Mateo** (“Licensee” Or “Customer”) and CapsuleTech, Inc. (“Capsule”), and is effective as of the effective date of the underlying Capsule Medical Device Information Platform Agreement (“Agreement”). This SOW is governed by the terms and conditions of the Capsule Medical Device Information Platform Agreement (“Agreement”) and incorporated by reference therein.

This document defines the engagement’s objectives, scope and assumptions based upon information gathered throughout the sales cycle and post-sales interviews. Modifications to information contained in this document occurring after approval will be considered a change in scope and managed through Capsule’s Change Control process.

CUSTOMER PROBLEM STATEMENT: *(Describe the problem that the install of Capsule Solution solves; include the business drivers)*

Customer seeking bids via RFP for Medical Device integration for Capsule High Acuity Solutions and Chart Express

CUSTOMER EXPECTATIONS: *(Describe expectations that will indicate success at the end of the project)*

Capsule to assist customer with full deployment of Medical Device Integration High and Low Acuity

A. STAKEHOLDERS:

TABLE 1: STAKEHOLDERS, CLINICAL SPONSOR, PROJECT TEAM				
ROLE	NAME	TITLE	EMAIL	PHONE
Executive Sponsor	TBD			
Project Manager	TBD			
System Administrator	TBD			
Clinical Engineering Lead	Yunuen Bautista	Lead Biomed	c_ybautista@smcgov.org	
Clinical Champion	TBD			

B. PROJECT SCOPE:

TABLE 2: SITES, LOCATION & TIMING SCOPE					
#	SITE NAME	LOCATION (CITY, STATE)	# BEDS	SOLUTION (MDIs, ALARMS, WAVEFORMS, ETC.)	GO-LIVE DATE
	San Mateo Medical Center	San Mateo, CA	69	Philips MDI and Chart Xpress	Nov 2024

TABLE 3: MEDICAL DEVICES							
#	FACILITY	ROOM LOCATION	QT Y	DEVICE TYPE (MONITOR, VENT, ANESTHESIA, ETC.)	MANUFACTURER	MODEL	CONNECTIVITY (GATEWAY, NEURON, AXON, ETC.)
	San Mateo	OR	4	Monitor	Philips	MP50	Neuron
	San Mateo	OR	4	Anesthesia	Draeger	A350	Neuron
	San Mateo	ICU/SCU	7	Monitor	Philips	MX550, X2, MR 200	Neuron
	San Mateo	ICU/SCU	7	Monitor	Philips	MX550, X2, MR 200	Philips Gateway
	San Mateo	ED	19	Monitor	Philips	MX550, MX400, MP2, X2	Neuron
	San Mateo	PACU	7	Monitor	Philips	MX450	Neuron
	San Mateo	Endo	2	Monitor	Philips	MX500	Neuron
	San Mateo	Resp	10	Ventilators	Draeger	Evita Infinity V500	Neuron
	San Mateo	Dialysis	3	Dialysis	Fresenius	2008T	Neuron
	San Mateo	2AB Med Surg	16	Telemetry	Philips	MX40	Philips Gateway
	San Mateo	2AB Med Surg	34	Spot Check	Welch Allyn	Connex 67 NXTX, 6000 Series	Chart Xpress
	San Mateo	3AB Psych	3	Spot Check	Welch Allyn	Connex 67 NXTX, 6000 Series	Chart Xpress
	San Mateo	ED	5	Spot Check	Welch Allyn	Connex 67 NXTX, 6000 Series	Chart Xpress
	San Mateo	PACU	3	Spot Check	Welch Allyn	Connex 67 NXTX, 6000 Series	Chart Xpress
	San Mateo	Infusion Center	3	Spot Check	Welch Allyn	Connex 67 NXTX, 6000 Series	Chart Xpress
	San Mateo	1A	6	Spot Check	Welch Allyn	Connex 67 NXTX, 6000 Series	Chart Xpress
	San Mateo	Correctional Health Div.	4	Spot Check	Philips	SureSigns VS2+	Chart Xpress
	San Mateo	Correctional Health Div. Jail	2	Spot Check	Philips	EarlyView VS30	Chart Xpress

TABLE 4: CONNECTIVITY/HARDWARE SCOPE		
SOLUTIONS	QUANTITY	NUMBER OF BEDS
Capsule Gateway		
Capsule Client		
Capsule Axon 110		
Capsule Axon 410		
Capsule Axon 810		
Philips Axon 120		
Philips Axon 420		
Philips Axon 421		
Philips Axon 820		
Perle Terminal Server		
Neuron – Vital Stream Fixed	47 + 3 Spare = 50	50
Neuron – Vital Stream Mobile	5	
Capsule Chart Xpress	60	TBD
Capsule Vitals Plus		
Capnography		

TABLE 5: FEATURE SCOPE	
PLATFORM	MONITORING
<input checked="" type="checkbox"/> High Availability	<input checked="" type="checkbox"/> Rapid Authentication
<input checked="" type="checkbox"/> Shared Configuration	<input type="checkbox"/> Rapid Patient Identification
<input type="checkbox"/> Secure Association	<input type="checkbox"/> Capsule EWSS
	<input type="checkbox"/> Single Device (with Vitals Plus)

TABLE 6: ADVANCED INTEGRATION SCOPE			
DEVICE	DDI	DATA STREAM (ALARMS, WAVEFORMS, VITALS, ETC.)	RECEIVING SYSTEM
Not in Scope for this Project			

TABLE 7: WAVEFORM SCOPE	
DEVICE	WAVEFORMS (LIST DESIRED WAVEFORMS)
Not in Scope for this Project	

C. SOLUTION ARCHITECTURE DIAGRAMS:

a. Proposed Solution State: Capsule Philips MDI Deployment and Chart Xpress

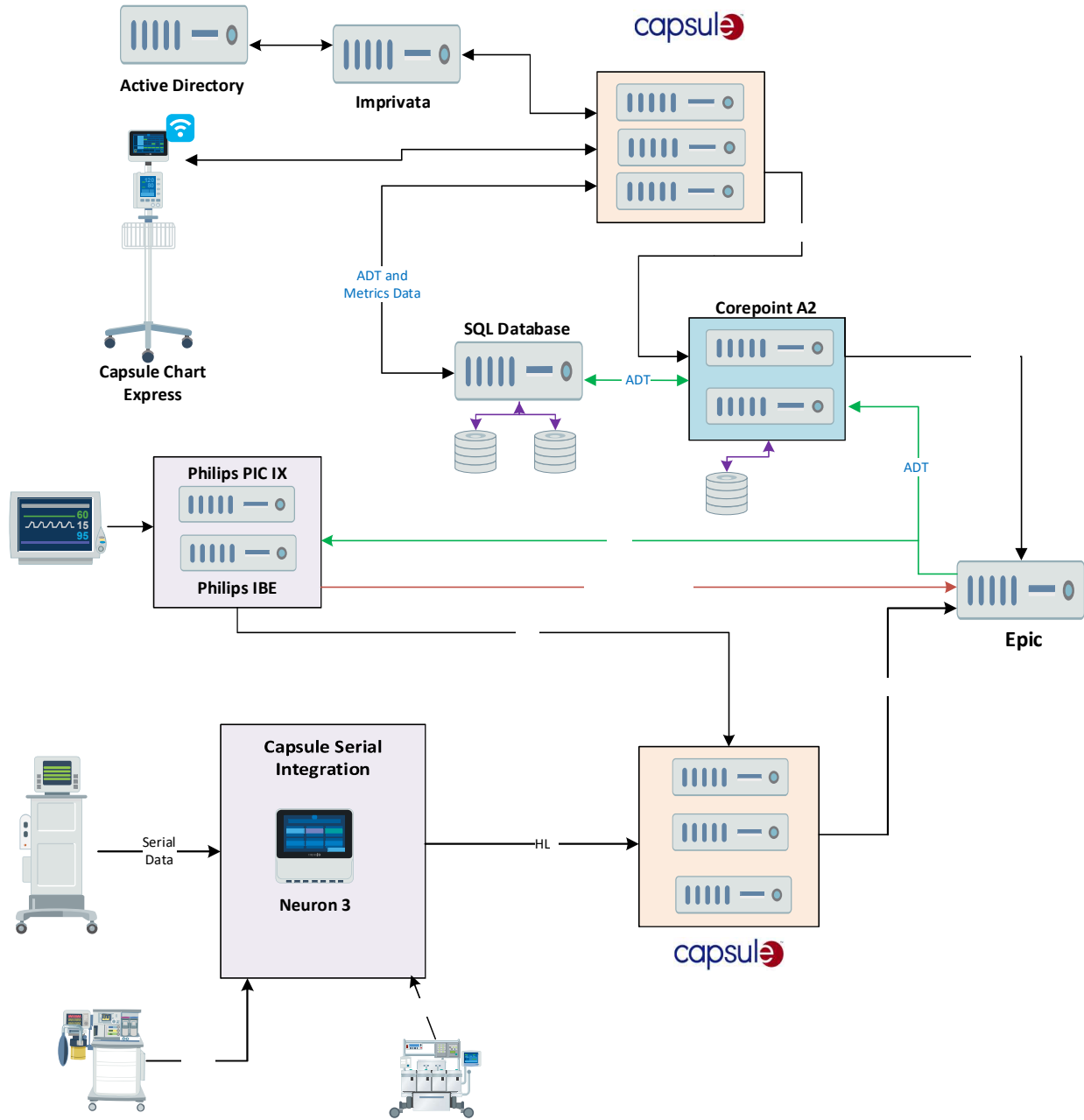

D. CAPSULE APPROACH, RESOURCES & DELIVERABLES:

a. Capsule Approach and Recommended Methodology:

Professional Services will support the project for up to two weeks after Go-Live, at which time the engagement will be transitioned to our support team. Go-Live is the day the Capsule system is activated and sending data to the production receiving system or endpoint.

PHASE 1: INITIATION	PHASE 2: PLANNING	PHASE 3: IMPLEMENTATION	PHASE 4: GO LIVE
<ul style="list-style-type: none"> • Introduce project team <ul style="list-style-type: none"> ○ Project Manager ○ Clinical Champion ○ System Administrator • Confirm scope / expectations • Gather technical requirements • Document architecture • Verify device types, quantities, and locations • Source mounts 	<ul style="list-style-type: none"> • Conduct project kickoff • Finalize project plan • Ship hardware • Build and install server(s) • Perform initial testing <ul style="list-style-type: none"> ○ Communications ○ LDAP/ADT/Wi-Fi • Deliver technical training • Lead clinical design sessions 	<ul style="list-style-type: none"> • Finalize clinical design and obtain signoff • Audit received hardware • Assemble and deploy hardware • Confirm production environment • Perform final testing <ul style="list-style-type: none"> ○ Unit ○ Functional ○ Integrated • Confirm all devices configured • Deliver Clinical Train-the-Trainer 	<ul style="list-style-type: none"> • Customer trains end users • Decide Go/No-Go • Perform production cutover • Go-live • Approve project closure • Transfer to Support

b. Capsule Resources:

- **Project Manager** – A Capsule project manager will be assigned to coordinate and schedule resources and activities, working in partnership with the hospital project manager. Primary responsibilities and activities include:
 - Serve as the primary Capsule point of contact
 - Coordinate and schedule Capsule resources
 - Conduct planning calls to define project scope, environment, resources, risks, and readiness
 - Prepare and lead kickoff
 - Review a project plan with tasks, responsibilities, deadlines, and deliverables
 - Support communication plan through regular status calls and reports
 - Facilitate delivery of hardware and software
 - Offer recommendations on best practices and facilitate issue resolution
 - Monitor and control project scope, schedule, and budget
 - Manage risk through identification, evaluation, response, and monitoring
 - Obtain end-user acceptance for the deployed solution
- **Technical Consultant & Clinical Consultant** – Capsule will provide consultant(s) and documentation on the solution. Consultants will provide expertise and support for hospital personnel responsible for configuring and maintaining the Capsule system. Primary responsibilities and activities include:
 - Provide server and interface specifications to ensure environment meets project requirements

- Lead technical design sessions to finalize architecture, data flow and interfaces
- Lead clinical design sessions on workflow, solution benefits and capabilities
- Assist with install and configuration of Capsule software
- Perform technical knowledge transfer through formal training
- Provide technical & clinical support, consulting & recommendations
- Support Communication, Functional & Integrated testing with receiving systems
- Provide technical expertise to support hospital with Capsule hardware deployment
- Engage clinical leadership to promote end user adoption and achieve high utilization
- Provide clinical training to super users to enable end-user training
- Support pre-live and go-live events

c. Capsule Deliverables

- Project activities will result in specific deliverables, such as system requirements, product datasheets, mounting guidelines, system diagram, project charter, roles & responsibilities, and project plan which will be provided to the Customer. As part of an ongoing communication plan, regular status calls and reports will provide accomplishments, cost and schedule variance analysis, risk, issues, and upcoming tasks.

E. CUSTOMER RESOURCES

- Primary hospital staff resources required for this engagement:
 - **Site Project Manager:** Serve as a primary point of contact, provide committed Customer and 3rd party resources, control scope, schedule, budget, and risk and provide project acceptance
 - **System Administrators:** Primary and secondary resources serve as technical contacts, install, and maintain the Capsule configuration, perform upgrades and back-ups, lead testing sessions, attend regular team meetings and act as a liaison between other hospital resources
 - **Biomedical or Clinical Engineer:** Primary and secondary resources assemble, deploy and support Capsule hardware according to the guidelines provided through Capsule training and product documentation
 - **Clinical Champion:** Serve as a primary clinical contact, provide leadership, participate in optimization activities, coordinate, and facilitate design and workflow discussions, identify super-users, provide subject matter expert support, and resolve conflicts as well as champion solution adoption
- Supporting hospital staff resources that may be required:
 - Network / IT / Server: Provide and configure server, network, and infrastructure in accordance with Capsule requirements
 - MSSQL DBA: Provide SQL infrastructure and access, facilitate installation and support deployment
 - Clinical Analyst: Provide guidance on flowsheet configuration and receiving system requirements
 - Subject Matter Experts: Provide guidance and documentation as needed
 - Third party Vendors: Provide guidance and documentation as needed

F. CUSTOMER RESPONSIBILITIES

- Provide infrastructure to meet Capsule's requirements and comply with agreed upon architecture, required by the solution but not expressly defined in the Capsule agreement:
 - Server count
 - Operating system
 - Third-party software
 - Mounts installed
 - Network cables/jacks and power cables installed
- Manage 3rd parties to provide support in an efficient and timely manner:
 - Receiving Systems
 - Device Manufacturers
 - ADT provider
- Ensure availability of appropriate interface type based on the solution deployed
 - Validated (non-critical care) or non-validated (critical care) data flow
 - ADT
- Provide access to all locations required for system installation, configuration, and training
- Provide written authorization to Capsule to ship specific equipment to a specific location
- Manage standard Location Codes across all systems and facilities or provide translations
- Define, document, and execute integration test plans specific to the unit where the solution is deployed

G. PROJECT ASSUMPTIONS AND LIMITATIONS

- All devices and data sources are connected and sending data 60 days prior to Go-Live
- Receiving systems will be built according to data parameters configured in Capsule solution
- Requirements for all in scope solutions will be promptly provided to Capsule
- HL7 messages will meet the requirements outlined in the Capsule HL7 Interface Specification and TCP/IP is the standard communication protocol
- Any vendor integration not noted in this document will require additional validation
- Capsule professional services will be provided remotely except where described in the Professional Services Offering
- Customer will own responsibility for Capsule hardware assembly and deployment, except where described in the Professional Services Offering
- Using a Train-the-Trainer approach, select hospital personnel will be trained and then train >80% of end-users in each area implementing the solution and workflow before go-live
- Customer will perform any site assessments necessary to identify hardware, mounting and infrastructure needs, based on the requirements provided by Capsule
- Customer's medical device model and firmware are supported by Capsule's current solution

H. CHANGE CONTROL PROCESS

Change is a part of any project and unplanned changes may occur. Deviations that impact scope, schedule or cost agreed upon in this Statement of Work will be subject to the following Change Control Process:

- A Change Order request will be submitted in writing to Capsule
- The project team will review the proposed change and determine the impact to scope, schedule and/or cost

- If the change requires additional cost, Capsule will determine the incremental cost and provide a quote
- The Change Order request and impact will be reviewed with the Customer, and if approved, receipt of a PO for the additional services, hardware or licenses will be obtained.
- **If the change impacts the go-live date, the Customer is responsible for the communication to all project stakeholders**

I. PROFESSIONAL SERVICES OFFERING:

The Professional Services estimate is based on Capsule's extensive experience in implementing medical device information platform using proven methodologies and a long track record of ensuring successful connectivity solution design and surveillance deployment. Our methodology is robust and responsive to individual project requirements and provides repeatability and a consistently high-quality Customer experience.

- The Professional Services estimate for this engagement is **\$49,280.00** and will be invoiced monthly as incurred.
- The Travel and Expense estimate for this engagement is **\$10,000.00** and will be invoiced monthly as incurred.
- The estimated duration of this project and corresponding Professional Service engagement is **9** months.
- Additional hours may be purchased at a per hour rate of \$215 for Technical Consulting or Clinical Lead and \$248 for Project Management.
- Mutually agreed upon changes in scope, duration, requirements, or design will result in a reassessment of the Professional Service offering.

Service Product	Deliverables	Capsule		Rate	Onsite or Remote	Total
Project Management	Start, Track & Close Project	60	Hours	\$248	Remote	\$14,880
Clinical Consulting	Clinical Requirements, Design and Clinical Status Calls	12	Hours	\$215	Onsite	\$2,580
System Implementation	Install and configure server environment(s)	20	Hours	\$215	Remote	\$4,300
Field Service	Admin Training/Hardware Orientation/Oversight on Hardware installation/Confirm hardware connections to server/Assist with unit testing	24	Hours	\$215	Onsite	\$5,160
	Assistance with onsite roll stand assembly and validation (1 unit) as part of training	4	Hours	\$215	Onsite	\$860
Integration Testing & Consulting Support	Testing/config support/technical support, consulting & recommendations	48	Hours	\$215	Remote	\$10,320
Clinical Training	Clinical End User training & Clinical Meetings	16	Hours	\$215	Remote	\$3,440
Go-Live Support	Technical & Clinical Support	36	Hours	\$215	Onsite	\$7,740
Total		220				\$49,280
Travel	Estimated travel & Expenses					\$10,000

J. SIGNATURES:

County of San Mateo

Signature: _____

Full Name: _____

Title: _____

Date: _____

Capsule

John McHutcheon

Electronically signed by: John McHutcheon
Reason: "I Approve"
Date: May 27, 2024 17:32 EDT

Signature: _____

Full Name: John McHutcheon

Title: Services & Solutions Delivery Leader

Date: May 27, 2024

SCHEDULE G

BUSINESS ASSOCIATE ADDENDUM

This Business Associate Addendum ("Addendum") is between CapsuleTech, Inc. ("Business Associate") and County of San Mateo ("Covered Entity"). This Addendum is entered into as part of the Medical Device Information Platform Agreement between the parties (the "Underlying Contract") and is incorporated therein by reference.

1. **BACKGROUND AND PURPOSE.** The Underlying Contract requires or permits Business Associate to be provided with, have access to or create Protected Health Information that is subject to the federal regulations issued pursuant to the Health Insurance Portability and Accountability Act ("HIPAA") and the HIPAA Rules, as modified by the Health Information Technology for Economic and Clinical Health ("HITECH") Act. All references to the "HIPAA Rules" are deemed to include all amendments to such rule contained in the HITECH Act and any accompanying regulations, and any other subsequently adopted amendments or regulations. This Addendum will supplement or amend the Underlying Contract only with respect to Business Associate's receipt, use or creation of PHI under the Underlying Contract to allow Covered Entity to comply with the HIPAA Rules. Except as so supplemented or amended, the terms of the Underlying Contract will continue unchanged and will apply with full force and effect to govern the matters addressed in this Addendum and the Underlying Contract.

2. **DEFINITIONS**
 - 2.1 Catch-all definition: The following terms used in this Addendum shall have the same meaning as those terms in the HIPAA Rules: Breach, Data Aggregation, Designated Record Set, Disclosure, Health Care Operations, Individual, Minimum Necessary, Notice of Privacy Practices, Protected Health Information, Required by Law, Secretary, Security Incident, Subcontractor, Unsecured Protected Health Information, Use.
 - 2.2 Specific definitions:
 - (a) "Business Associate" shall generally have the same meaning as the term "business associate" at 45 CFR 160.103, and in reference to the party to this agreement, shall mean the Business Associate named above.
 - (b) "Covered Entity" shall generally have the same meaning as the term "covered entity" at 45 CFR 160.103, and in reference to the party to this agreement, shall mean the Covered Entity named above.
 - (c) "HIPAA Rules" shall mean the Privacy, Security, Breach Notification and Enforcement Rules at 45 CFR Part 160 and Part 164.

3. **OBLIGATIONS AND ACTIVITIES OF BUSINESS ASSOCIATE**
 - 3.1 Business Associate agrees to:
 - (a) Not use or disclose protected health information other than as permitted or required by the Addendum or as required by law;
 - (b) Use appropriate safeguards, and comply with Subpart C of 45 CFR Part 164 with respect to electronic protected health information, to prevent use or disclosure of protected health information other than as provided for by the Addendum;
 - (c) Report to Covered Entity any use or disclosure of protected health information not provided for by the Addendum of which it becomes aware, including breaches of unsecured protected health information as required at 45 CFR 164.410, and any security incident of which it becomes aware;

- (d) In accordance with 45 CFR 164.502(e)(1)(ii) and 164.308(b)(2), if applicable, ensure that any subcontractors that create, receive, maintain, or transmit protected health information on behalf of the Business Associate agree to the same restrictions, conditions, and requirements that apply to the Business Associate with respect to such information;
- (e) Make available protected health information in a designated record set to the Covered Entity as necessary to satisfy Covered Entity's obligations under 45 CFR 164.524;
- (f) Make any amendment to protected health information in a designated record set as directed or agreed to by the Covered Entity pursuant to 45 CFR 164.526, or take other measures as necessary to satisfy Covered Entity's obligations under 45 CFR 164.526;
- (g) Maintain and make available the information required to provide an accounting of disclosures to the Covered Entity as necessary to satisfy Covered Entity's obligations under 45 CFR 164.528;
- (h) To the extent the Business Associate is to carry out one or more of Covered Entity's obligations under Subpart E of 45 CFR Part 164, comply with the requirements of Subpart E that apply to the Covered Entity in the performance of such obligations; and
- (i) Make its internal practices, books and records available to the Secretary for purposes of determining compliance with the HIPAA Rules.

3.2 **Permitted Uses and Disclosures by Business Associate.**

- (a) Business Associate may use or disclose protected health information as necessary to perform the services set forth in Underlying Contract.
- (b) Business Associate may use or disclose protected health information as required by law.
- (c) Business Associate agrees to make uses and disclosures and requests for protected health information consistent with Covered Entity's minimum necessary policies and procedures as provided to Business Associate.
- (d) Business Associate may de-identify any and all PHI created or received by Business Associate under this Addendum; provided that the de-identification conforms to the requirements of the Privacy Rule . Such resulting de-identified information would not be subject to the terms of this Addendum and may be used and disclosed on Philips Capsule's own behalf.
- (e) Business Associate may not use or disclose protected health information in a manner that would violate Subpart E of 45 CFR Part 164 if done by Covered Entity, except for the specific uses and disclosures set forth in this Addendum.
- (f) Business Associate may disclose protected health information for the proper management and administration of Business Associate or to carry out the legal responsibilities of the Business Associate, provided the disclosures are required by law, or Business Associate obtains reasonable assurances from the person to whom the information is disclosed that the information will remain confidential and used or further disclosed only as required by law or for the purposes for which it was disclosed to the person, and the person notifies Business Associate of any instances of which it is aware in which the confidentiality of the information has been breached.
- (g) Business Associate may provide data aggregation services relating to the health care operations of the Covered Entity.

4. **OBLIGATIONS OF COVERED ENTITY**

4.1 Provisions for Covered Entity to Inform Business Associate of Privacy Practices and Restrictions.

- (a) Covered Entity shall notify Business Associate of any limitations in the notice of privacy practices of Covered Entity under 45 CFR 164.520, to the extent that such limitation may affect Business Associate's use or disclosure of protected health information.

- (b) Covered Entity shall notify Business Associate of any changes in, or revocation of, the permission by an individual to use or disclose his or her protected health information, to the extent that such changes may affect Business Associate's use or disclosure of protected health information.
- (c) Covered Entity shall notify Business Associate of any restriction on the use or disclosure of protected health information that Covered Entity has agreed to or is required to abide by under 45 CFR 164.522, to the extent that such restriction may affect Business Associate's use or disclosure of protected health information.

4.2 **Permissible Requests by Covered Entity.**

Covered Entity shall not request Business Associate to use or disclose protected health information in any manner that would not be permissible under Subpart E of 45 CFR Part 164 if done by Covered Entity, except for the specific uses and disclosures set forth in Section 3.2.

5. **TERM AND TERMINATION**

- 5.1 **Term.** The Term of this Addendum shall be effective as of the effective date of the Underlying Contract, and shall terminate on termination of the Underlying Contract or on the date Covered Entity terminates for cause as authorized in Section 5.2, whichever is sooner.
- 5.2 **Termination for Cause.** Business Associate authorizes termination of this Addendum by Covered Entity, if Covered Entity determines Business Associate has violated a material term of the Addendum and Business Associate has not cured the breach or ended the violation within the time specified by Covered Entity.
- 5.3 **Obligations of Business Associate upon Termination.** Upon termination of this Addendum for any reason, Business Associate agrees to return or destroy all PHI received from, or created or received by the Business Associate on behalf of the Covered Entity, that the Business Associate still maintains in any form and retain no copies of such information or, if such return or destruction is not feasible, extend the protections of this Addendum to the information and limit further uses and disclosures to those purposes that make the return or destruction of the information unfeasible.
- 5.4 **Survival.** The obligations of Business Associate under this Section 5 shall survive the termination of this Addendum.

6. **MISCELLANEOUS**

- 6.1 **Regulatory References.** A reference in this Addendum to a section in the HIPAA Rules means the section as in effect or as amended.
- 6.2 **No Third Party Beneficiaries.** Except as expressly stated in the HIPAA Rules, the parties to this Addendum do not intend to create any rights in any third parties.
- 6.3 **Privilege.** No attorney-client, accountant-client or other legal privilege will be deemed waived by Business Associate or Covered Entity as a result of this Addendum.
- 6.4 **Interpretation.** Any ambiguity in this Addendum shall be interpreted to permit compliance with the HIPAA Rules.
- 6.5 **Amendment.** The parties agree to take such action as is necessary to amend this Addendum from time to time as is necessary for compliance with the requirements of the HIPAA Rules and any other applicable law.

SCHEDULE H

TAX EXEMPT STATUS

Request for Sales Tax Exemption Certificate

In order for Philips Capsule to comply with state and local sales tax law requirements, it is necessary that we have in our files a properly executed exemption certificate from all our customers who claim sales tax exemption. If we do not have this certificate, we are obligated to collect the tax for the state in which the product is delivered.

Your cooperation in completing this request will be appreciated and will facilitate the efficient preparation of your invoices with regards to sales tax. If you should have any questions about this request please contact us as set forth below:

Mail:

CapsuleTech, Inc.
Attn: Finance Department
222 Jacobs Street
Cambridge, MA 02141

Email:

accounting.us@capsuletech.com

Fax:

+1 978-475-2980

Please select one of the following statements and sign below:

Licensee: _____

is Tax Liable.

is Tax Exempt and has attached a copy of our Tax Exemption Certificate.

Signature: _____

Print Name: _____

Date: _____

SCHEDULE I

FACILITIES

(to be inserted if applicable)







San Mateo MDIP final for execution

Final Audit Report

2024-05-27

Created:	2024-05-27
By:	Carrie Jones (carrie.jones@philips.com)
Status:	Signed
Transaction ID:	CBJCHBCAABAAzcIQUrjCjFqB84XtMfuaFN1SvjOvqMCF

"San Mateo MDIP final for execution" History

-  Document created by Carrie Jones (carrie.jones@philips.com)
2024-05-27 - 7:14:43 PM GMT- IP address: 155.190.21.7
-  Document emailed to john.mchutcheon@philips.com for signature
2024-05-27 - 7:23:32 PM GMT
-  Email viewed by john.mchutcheon@philips.com
2024-05-27 - 9:28:51 PM GMT- IP address: 98.229.113.15
-  Signer john.mchutcheon@philips.com entered name at signing as John McHutcheon
2024-05-27 - 9:32:04 PM GMT- IP address: 98.229.113.15
-  Document e-signed by John McHutcheon (john.mchutcheon@philips.com)
Signing Reasons
"I Approve" (Signature 2)
"I Approve" (Signature 1)
Signature Date: 2024-05-27 - 9:32:06 PM GMT - Time Source: server- IP address: 98.229.113.15
-  Agreement completed.
2024-05-27 - 9:32:06 PM GMT